

LOU MARTIN &
ASSOC INC

2107 DANBURY DRIVE
SAN ANTONIO, TEXAS 78217

PHONE: (210) 930-8181
FAX: (210) 930-8184

**COMPONENT MAINTENANCE MANUAL
WITH
ILLUSTRATED PARTS LIST**

**Decorative Window Shade Assembly
A320-113M2165**

Second Issue: JAN 10/05

25-23-08

JAN 10/05

Lou Martin & Assoc., Inc.
Component Maintenance Manual

25-23-08

Lou Martin & Assoc., Inc.
Component Maintenance Manual

25-23-08

Lou Martin & Assoc., Inc.
Component Maintenance Manual

25-23-08

Lou Martin & Assoc., Inc.
Component Maintenance Manual

TABLE OF CONTENTS

	Page
RECORD OF REVISIONS	1
RECORD OF TEMPORARY REVISIONS	1
SERVICE BULLETIN LIST	1
TABLE OF CONTENTS	1
LIST OF EFFECTIVE PAGES	1
INTRODUCTION	1
1. General	1
2. Layout of manual	1
3. Revision of the document	2
4. Certification of operations	3
5. WARNINGS-CAUTIONS-NOTES	3
6. List of Abbreviations	4
DESCRIPTION AND OPERATION	1
1. Description	1
2. Technical Data	3
TESTING AND FAULT ISOLATION	1001
1. Testing	1001
2. Fault Isolation	1002
SCHEMATIC AND WIRING DIAGRAMS	NOT APPLICABLE
UNINSTALLING WINDOW ASSY.	3001
1. General	3001
2. Job set-up information	3001
3. Preliminary Steps	3001
4. Upper window removal	3002
5. Lower window clip removal	3003
DISASSEMBLY	4001
1. General	4001
2. Job set-up information	4001
3. Preliminary Steps	4001
4. Decorative mask removal	4002
5. Inner lens removal	4002
6. Blind mod. assy. removal	4002
CLEANING	5001
1. General	5001
2. Job set-up information	5001
3. Procedure	5002

Lou Martin & Assoc., Inc.
Component Maintenance Manual

AIRWORTHINESS LIMITATIONS	6001
1. General	6001
INSPECTION/REPLACEMENT & REPAIR	7001
1. General	7001
2. Job set-up information	7001
3. Inspection of window unit	7002
4. Replacement of Parts	7002
5. Replacement procedure for outer lens	7003
6. Replacement procedure for broken shade string	7004
7. Replacement procedure for a damaged inner lens	7005
ASSEMBLY	8001
1. General	8001
2. Job set-up information	8001
3. Blind mod. Reattachment	8002
4. Inner Lens reattachment	8002
5. Decorative Mask reattachment	8002
FITS AND CLEARANCES	9001
1. General	9001
2. Clearances	9001
SPECIAL TOOLS, FIXTURES, EQUIPMENT	10001
1. Special tools, fixtures and equipments	10001
STORAGE	11001
1. General	11001
ILLUSTRATED PARTS LIST	INTRO IPL 1
1. Introduction	INTRO IPL 1
2. How to use the Illustrated Parts List	INTRO IPL 2
3. Alphanumerical Index	ALPHANUMERICAL INDEX
DETAILED PARTS LIST	12001

TABLE OF CONTENTS

PAGE 2

JAN 10/05

25-23-08

Lou Martin & Assoc., Inc.
Component Maintenance Manual

LIST OF EFFECTIVE PAGES

SUBJECT	PAGE	DATE	SUBJECT	PAGE	DATE
TITLE PAGE	1	JAN 10/05	DISASSEMBLY	4001	JAN 10/05
				4002	JAN 10/05
RECORD OF REVISION	1	JAN 10/05	CLEANING	5001	JAN 10/05
				5002	JAN 10/05
RECORD OF TEMPORARY REVISIONS	1	JAN 10/05		5003	JAN 10/05
				5004	BLANK
SERVICE BULLERIN LIST	1	JAN 10/05	AIRWOTHINESS LIMITATIONS	6001	JAN 10/05
				6002	BLANK
TABLE OF CONTENTS	1	JAN 10/05	INSPECTION/	7001	JAN 10/05
	2	JAN 10/05	REPLACEMENT	7002	JAN 10/05
			& REPAIR	7003	JAN 10/05
				7004	JAN 10/05
LSIT OF EFFECTIVE PAGES	1	JAN 10/05		7005	JAN 10/05
	2	JAN 10/05	ASSEMBLY	8001	JAN 10/05
				8002	JAN 10/05
INTRODUCTION	1	JAN 10/05		8003	JAN 10/05
	2	JAN 10/05			
	3	JAN 10/05	FITS AND	9001	JAN 10/05
	4	JAN 10/05	CLEARANCES	9002	JAN 10/05
	5	JAN 10/05			
	6	BLANK	SPECIAL TOOLS, FIXTURES, AND EQUIPMENT	10001	JAN 10/05
DESCRIPTION AND OPERATION	1	JAN 10/05			
	2	JAN 10/05			
	3	JAN 10/05	STORAGE	11001	JAN 10/05
TESTING AND FAULT	1	JAN 10/05	ILLUSTRATED	INTRO IPL 1	JAN 10/05
	2	JAN 10/05	PARTS LIST	INTRO IPL 2	JAN 10/05
				INTRO IPL 3	JAN 10/05
				INTRO IPL 4	JAN 10/05
UNINSTALLING WINDOW ASSY.	3001	JAN 10/05		INTRO IPL 5	JAN 10/05
	3002	JAN 10/05		INTRO IPL 6	BLANK
	3003	JAN 10/05			
	3004	JAN 10/05			

LIST OF EFFECTIVE PAGES
PAGE 1
JAN 10/05

Lou Martin & Assoc., Inc.
Component Maintenance Manual

LIST OF EFFECTIVE PAGES

SUBJECT	PAGE	DATE
ALPHANUMERICAL	1	JAN 10/05
INDEX	2	JAN 10/05
DETAILED	12001-0	JAN 10/05
PARTS LIST	12001-1	JAN 10/05
	12002-0	JAN 10/05
	12002-1	JAN 10/05
	12003-0	JAN 10/05
	12003-1	JAN 10/05
	12004-0	JAN 10/05
	12004-1	JAN 10/05
	12005-0	JAN 10/05
	12005-1	JAN 10/05

Lou Martin & Assoc., Inc.
Component Maintenance Manual

Introduction

TASK 25-23-08-990-801

1. General

- A. This document writing follows the directives of the “A.T.A Specification No. 100” updating N° 36. The instructions in this manual give the information necessary to do maintenance functions ranging from simple checks and replacement to complete shop type repair for the equipment, manufactured and supported by:

Lou Martin & Assoc., Inc. 2107 Danbury Drive San Antonio, TX. 78217 USA Tel.: (210) 930-8181 – Fax: (210) 930-8184

- B. This document is applicable to the following equipment:

Decorative Window Shade Assy. A320-113M2165

TASK 25-23-08-990-802

2. Layout of manual

- A. This manual contains a general description and operation followed by data for maintenance, repair, disassembly and assembly of the equipment. This is followed by an illustrated parts list (IPL), which gives detailed information.
- B. The manual is divided into separate sections:
- (1) Title Page
 - (2) Record of Revisions
 - (3) Table of Contents
 - (4) Introduction
 - (5) Procedures and IPL Sections

INTRO
PAGE 1
JAN 10/05

25-23-08

Lou Martin & Assoc., Inc.
Component Maintenance Manual

- C. This manual will be updated as required by revisions: Service Bulletins may be issued separately. Their effect on this manual will be made evident by reissue of the appropriate list of Service Bulletins.

TASK 25-23-08-990-803

3. Revision of the document

- A. Two types of revisions of the manual are used to follow the evolution of this equipment/

(1) Normal revision

- (a) Normal revisions are periodically issued.
- (b) They are printed on white paper
- (c) A List of Revisions gives a better follow-up of these revisions.
- (d) The changes in the text are shown by a vertical line drawn in the left margin.

(2) Temporary revision

- (a) Temporary revisions can be issued in advance of the normal revision.
- (b) They are printed on yellow paper.
- (c) A List of Temporary Revisions gives their follow-up.
- (d) A letter comes with these temporary revisions to give all the necessary information about the insertion of these revisions.

INTRO
PAGE 2
JAN 10/05

25-23-08

Lou Martin & Assoc., Inc.
Component Maintenance Manual

- (3) General rules for the insertion of temporary revisions
 - (a) A yellow page (with a higher sequential number) can replace a yellow page.
 - (b) A yellow page cannot replace a white page.

TASK 25-23-08-990-804

4. Certification of operation

- A. The maintenance operations described in the present COMPONENT MAINTENANCE MANUAL have been checked in the manufacturer's workshop by observing the disassembly, assembly, testing, and trouble-shooting instructions detailed in this document.

TASK 25-23-08-990-805

5. WARNINGS-CAUTIONS-NOTES

- A. Special adjuncts to the text are expressed by the following headings:

WARNING : CALL ATTENTION FOR THE USE OF MATERIALS, PROCESSES, METHODS, PROCEDURES OR TOLERANCES WHICH MUST BE ADHERED TO CAREFULLY IN ORDER TO AVOID ANY INJURY.

CAUTION: CALL ATTENTION TO METHODS AND PROCEDURES, WHICH MUST BE ADHERED TO IN ORDER TO AVOID DAMAGE TO EQUIPMENT.

NOTE: Call attention to methods, which make the procedures easier.

INTRO
PAGE 3
JAN 10/05

25-23-08

Lou Martin & Assoc., Inc.
Component Maintenance Manual

TASK 25-23-08-990-805

6. List of Abbreviations

ASSY	: ASSEMBLY
ATA	: AIR TRANSPORT ASSOCIATION OF AMERICA
FAA	: FEDERAL AVIATION ADMINISTRATION
FAR	: FEDERAL AVIATION REGULATION
IPL	: ILLUSTRATED PARTS LIST
LB.	: POUND
MS	: MILITARY STANDARD
NAS	: NATIONAL AEROSPACE STANDARD
REV	: REVISION
SB	: SERVICE BULLETINS
TR	: TEMPORARY REVISION

INTRO
PAGE 4
JAN 10/05

25-23-08

Lou Martin & Assoc., Inc.
Component Maintenance Manual

PAGE INTENTIONALLY LEFT BLANK

INTRO
PAGE 5
JAN 10/05

25-23-08

Lou Martin & Assoc., Inc.
Component Maintenance Manual

TASK 25-23-08-870-801

DESCRIPTION AND OPERATION

1. Description

A. General

Basically, the decorative window shade assy. is made of a fiberglass shell, blind assy., inner & outer lenses and a decorative mask.

For attachment, the cabin window assy. is supplied with two thru inserts to pick-up existing attach point for upper attachment and three Airbus clips for lower attachment.

B. Composition

(See FIGURE 1 / GRAPHIC 25-23-08-991-001 next page)

Lou Martin & Assoc., Inc.
Component Maintenance Manual

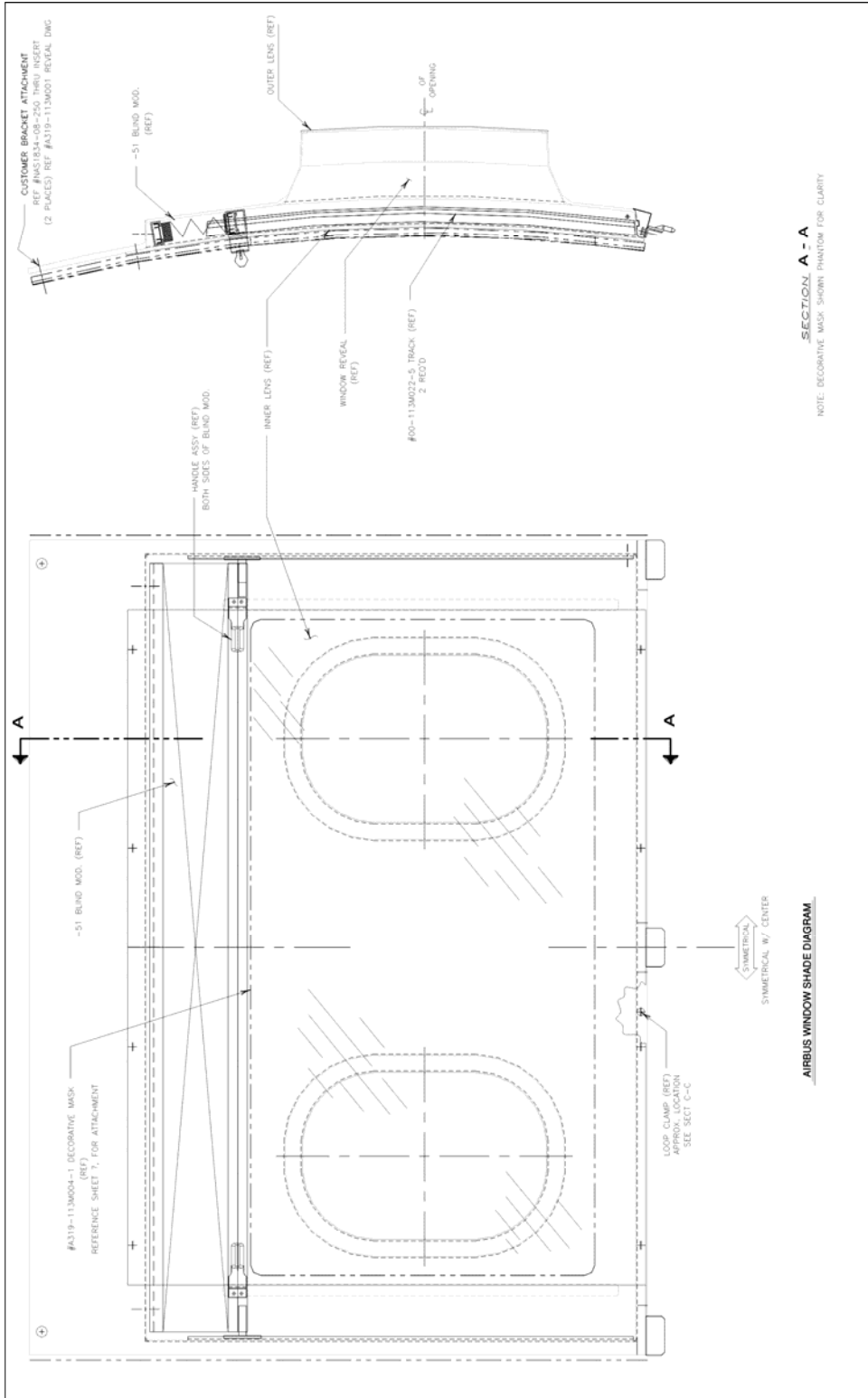

FIGURE 1 / GRAPHIC 25-23-08-991-001

Lou Martin & Assoc., Inc.
Component Maintenance Manual

TASK 25-23-08-870-802

2. Technical data

ASSY.	REVEAL	INNER LENS	OUTER LENS	BLIND MOD.	DECORATIVE MASK	HANDLE ASSY.
-1	A319-113M001-1	A320-113M2165-111	A320-113M2165-109	A320-113M2165-51	A319-113M004-1	A320-113M2165-41
-5	A319-113M001-43	A320-113M2165-115	A320-113M2165-109	A320-113M2165-55	A319-113M004-73	A320-113M2165-41
-7	A319-113M001-45	A320-113M2165-117	A320-113M2165-109	A320-113M2165-57	A319-113M004-75	A320-113M2165-41
-9	A319-113M001-55	A320-113M2165-111	A320-113M2165-109	A320-113M2165-51	A319-113M004-1	A320-113M2165-41
-11	A319-113M001-11	A320-113M2165-121	A320-113M2165-109	A320-113M2165-61	A319-113M004-11	A320-113M2165-41
-13	A319-113M001-13	A320-113M2165-123	A320-113M2165-109	A320-113M2165-63	A319-113M004-13	A320-113M2165-41
-15	A319-113M001-51	A320-113M2165-125	A320-113M2165-109	A320-113M2165-65	A319-113M004-61	A320-113M2165-43
-17	A319-113M001-17	A320-113M2165-127	A320-113M2165-109	A320-113M2165-67	A319-113M004-17	A320-113M2165-43
-19	A319-113M001-53	A320-113M2165-129	A320-113M2165-109	A320-113M2165-69	A319-113M004-63	A320-113M2165-43
-21	A319-113M001-41	A320-113M2165-131	A320-113M2165-109	A320-113M2165-71	A319-113M004-65	A320-113M2165-41
-23	A319-113M001-47	A320-113M2165-133	A320-113M2165-109	A320-113M2165-73	A319-113M004-67	A320-113M2165-41
-25	A319-113M001-25	A320-113M2165-135	A320-113M2165-109	A320-113M2165-75	A319-113M004-25	A320-113M2165-41
-27	A319-113M001-57	A320-113M2165-111	A320-113M2165-109	A320-113M2165-51	A319-113M004-1	A320-113M2165-41
-29	A319-113M001-55	A320-113M2165-111	A320-113M2165-109	A320-113M2165-51	A319-113M004-1	A320-113M2165-41
-31	A319-113M001-1	A320-113M2165-111	A320-113M2165-109	A320-113M2165-51	A319-113M004-77	A320-113M2165-41
-32	A319-113M001-1	A320-113M2165-111	A320-113M2165-109	A320-113M2165-51	A319-113M004-79	A320-113M2165-41
-33	A319-113M001-33	A320-113M2165-139	A320-113M2165-109	A320-113M2165-79	A319-113M004-33	A320-113M2165-41
-35	A319-113M001-35	A320-113M2165-141	A320-113M2165-109	A320-113M2165-81	A319-113M004-35	A320-113M2165-41
-37	A319-113M001-37	A320-113M2165-143	A320-113M2165-109	A320-113M2165-83	A319-113M004-69	A320-113M2165-41
-39	A319-113M001-39	A320-113M2165-145	A320-113M2165-109	A320-113M2165-85	A319-113M004-71	A320-113M2165-41

FIGURE 2/ GRAPHIC 25-23-08-991-002

Lou Martin & Assoc., Inc.
Component Maintenance Manual

TESTING AND FAULT ISOLATION

TASK 25-23-08-700-801

1. Testing

A. General

- (1) The tests check the different adjustments, components and mechanisms of the window shade unit.
- (2) The defective parts must be repaired in workshops or can be replaced by serviceable parts.

B. Job set-up information

- (1) Tools, fixtures, equipment and materials

NOTE: Refer to “SPECIAL TOOLS, FIXTURE AND EQUIPMENTS”
for full details on the items used.

C. Procedure

- (1) Make sure the shade unit operates with the desired tension

Lou Martin & Assoc., Inc.
Component Maintenance Manual

TASK 25-23-08-700-802

2. Fault isolation

- A. Faults you can find during the operations are given here under together with their probable causes and their corrective actions.
- B. After the necessary corrective action is done, do an inspection of the window unit to make sure that the fault is corrected.
- C. Mechanical fault isolation

TROUBLE	POSSIBLE CAUSE	CORRECTION
SHADE ASSY.		
Shade assy. does not operate with the desired tension	Incorrect tension	Adjust spring by resetting ball catch as required to add release tension (Refer to section 3)
DECORATIVE MASK		
Panel is loose	Screws holding mask in place are loose	Tighten attachment screws

Lou Martin & Assoc., Inc.
Component Maintenance Manual

TASK 25-23-08-700-802

3. Procedure for adjusting shade tension

- A. Remove window shade unit that requires adjustment from aircraft. See (“UNINSTALLING WINDOW SHADE UNIT”, section 6 & 7 pages 3002 & 3003)

NOTE: Assure window unit lenses, plated parts, and decorative mask parts are protected at all times when work is being done.

- B. Locate tension spring at lower back of window housing. Tension assy. is secured in place w/ stop nut and loop clamp.
- C. To remove loop clamp, un-screw stop nut and slide clamp off retainer clip
- D. Slide loop clamp & shrink tube to side w/ spring to access ball catch assy.
- E. Adjust ball catch assy to desired tension (See FIGURE 3, GRAPHIC 25-23-08-991-003 page 3004) next page. Make adjustments one link at a time. Optimal tension does not allow blind mod. to fall freely. Run shade up and down to assure it operates smoothly.
- F. When desired tension is achieved, complete steps C & D in reverse order to complete adjustment.
- G. Re-install window unit. See (“UNINSTALLING WINDOW SHADE UNIT”, section 6 & 7 pages 3002 & 3003). Complete these steps in reverse order.

Lou Martin & Assoc., Inc.
Component Maintenance Manual

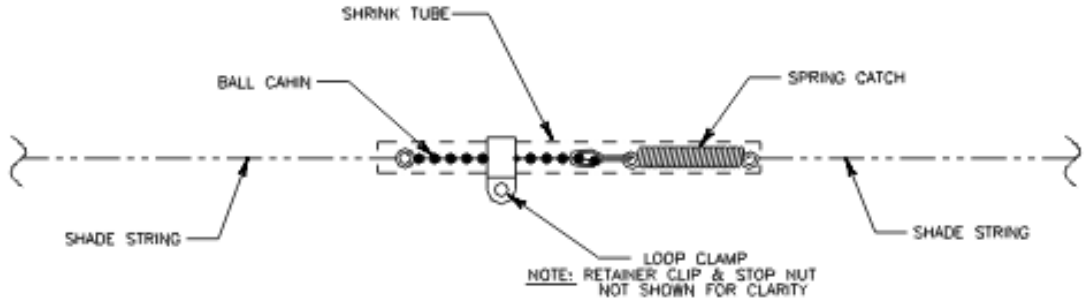

TENSION ASSY.

TO LOSSEN TENSION DISCONNECT BALL CHAIN FROM CATCH, AND RE-ATTACH AT LONGER LOCATION

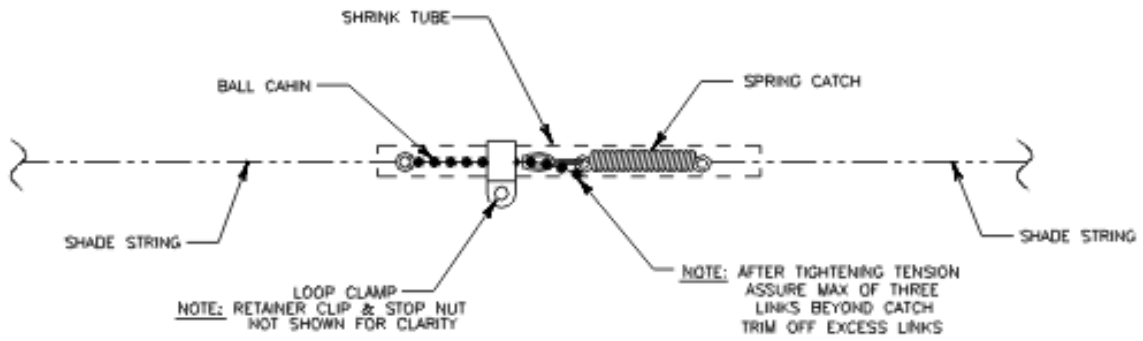

TENSION ASSY.

TO TIGHTEN TENSION DISCONNECT BALL CHAIN FROM CATCH, AND RE-ATTACH AT SHORTER LOCATION

FIGURE 3, GRAPHIC 25-23-08-991-003
Showing tension adjustment

Lou Martin & Assoc., Inc.
Component Maintenance Manual

PAGE INTENTIONALLY LEFT BLANK

PAGE 1005
JAN 10/05

25-23-08

Lou Martin & Assoc., Inc.
Component Maintenance Manual

UNINSTALLING WINDOW SHADE ASSY.

TASK 25-23-08-000-801

1. General

- A. The overhaul instructions contained in this manual are usually implemented in mechanical overhaul workshops.
- B. Avoid removing identification plates, unless manufacturer authorization.
- C. Assure window unit inner and outer lens, and any decorative plated parts are protected at all times when removed from the aircraft.
- D. When removing and transporting the window unit assure the shade is in the up position.

TASK 25-23-08-940-801

2. Job set-up information

- A. Tools, Fixtures, equipment and materials
None.

TASK 25-23-08-000-802

3. Preliminary Steps

- A. Before the uninstalling, make note of the window assy. location for efficient re-installation and to prevent errors.

Lou Martin & Assoc., Inc.
Component Maintenance Manual

TASK 25-23-08-040-801

4. Upper window removal (Refer to FIGURE 4/ GRAPHIC 25-23-08-991-004)
 - A. Remove valance panel according to Sogerma Spec. DIT/BC/2165/015/04.
 - B. Remove curtain cartridge according to Sogerma Spec. DIT/BC/2165/015/04.
 - C. To remove upper window attachment, refer to FIGURE 4/ GRAPHIC 25-23-08-991-004 steps 1 & 2. See page 3004

Lou Martin & Assoc., Inc.
Component Maintenance Manual

TASK 25-23-08-040-802

5. Lower window removal (Refer FIGURE 4/ GRAPHIC 25-23-08-991-004)
 - A. To remove lower window attachment, refer FIGURE 4/ GRAPHIC 25-23-08-991-004 step 3. See next page.

Lou Martin & Assoc., Inc.
Component Maintenance Manual

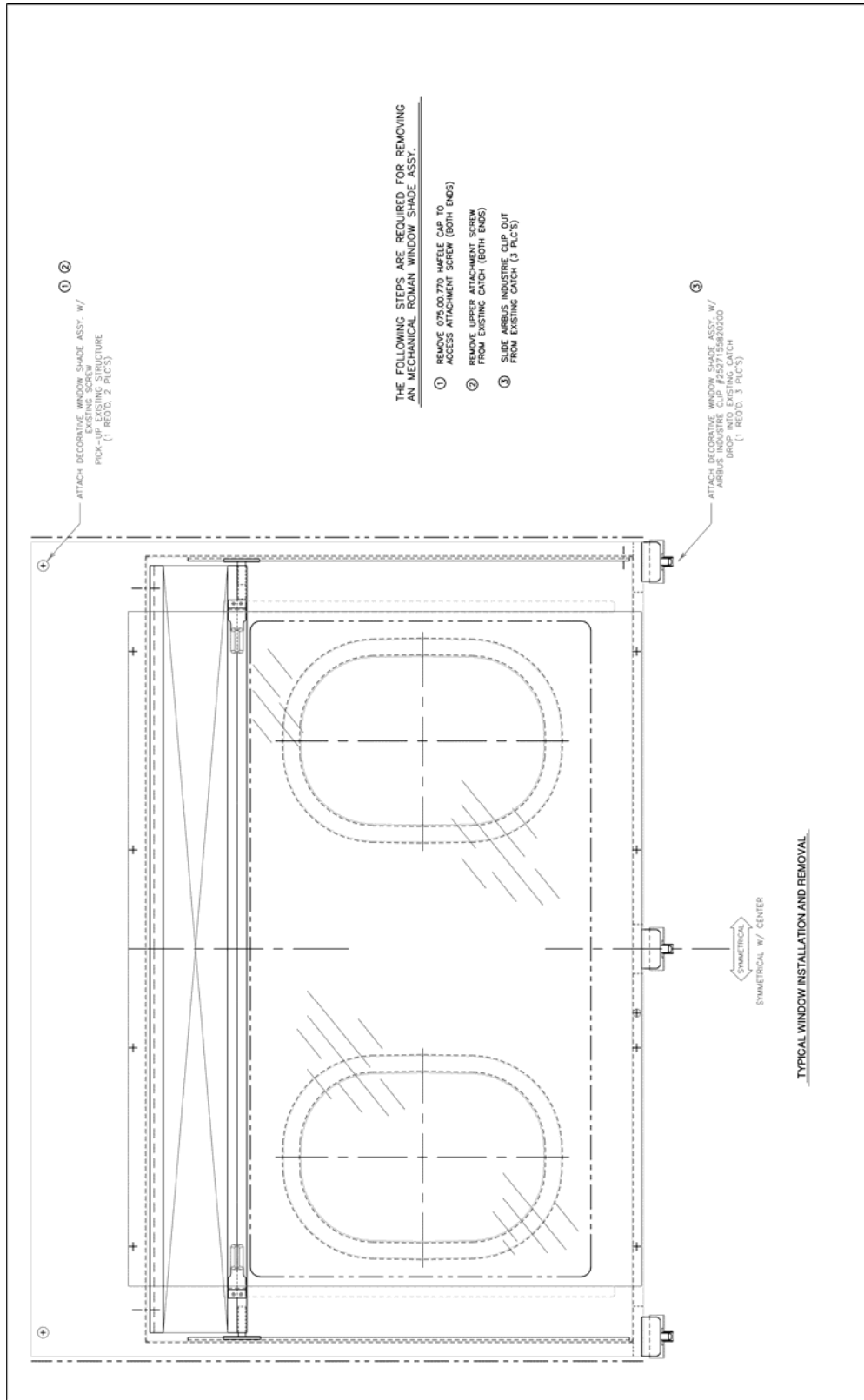

FIGURE 4/ GRAPHIC 25-23-08-991-004

Lou Martin & Assoc., Inc.
Component Maintenance Manual

DISASSEMBLY

TASK 25-23-08-000-803

1. General

- A. The overhaul instructions contained in this manual are usually implemented in mechanical overhaul workshops.
- B. Avoid removing identification plates, unless manufacturer authorization.
- C. Only disassemble what is necessary to do the repairs or to replace defective part(s).
- D. When applying the following instructions, never disassemble those components, which have been proved to be in good condition after inspection unless their disassembly is necessary to get access to the defective part.
- E. All the parts must be identified before the disassembly in order to prevent the error and to make the reassembly easier.
- F. For the identification of damage or functional failure refer to:

“INSPECTION/REPLACEMENT & REPAIR” Page 7002

TASK 25-23-08-940-803

2. Job set-up information

- A. Tools, fixtures, equipment and materials
None.

TASK 25-23-08-000-804

3. Preliminary Steps

- A. Before the disassembly, put marks on all the parts to help the reassembly and to prevent errors.

Lou Martin & Assoc., Inc.
Component Maintenance Manual

TASK 25-23-08-040-804

4. Decorative mask removal

- A. Remove mask attachment screws from back side of window assy (5 places).
- B. Gently move mask left or right to access and remove decorative handle screws.
- C. Remove mask

NOTE: Assure the decorative mask & handles are protected at all times.

TASK 25-23-08-040-805

5. Inner lens removal

- A. Remove screws holding the inner lens in place.
- B. Remove inner lens protecting both sides from damage.

TASK 25-23-08-040-806

6. Blind mod. assy. removal

- A. Locate Tension spring at lower back of window housing (reveal). Spring is secured in place w/ stop nut & loop clamp.
- B. To remove loop clamp, un-screw stop nut and slide clamp off retainer clip.
- C. Slide loop clamp & shrink tube to side w/ spring to access tension assy.
- D. Carefully un-tie shade string from tension assy. Assure that all components (ball chain, spring, shrink tube, loop clamp, & stop nut) are stored in a safe location to prevent damage or loss of parts during service.
- E. Upper blind mod. is attached with two or three screws and stop nuts depending on size, remove stop nuts to free blind upper rail.
- F. Slide blind mod lower rail to top of reveal to free glides from slide track, thus freeing blind mod. from reveal.

Lou Martin & Assoc., Inc.
Component Maintenance Manual

CLEANING

TASK 25-23-08-100-801

1. General

- A. A full cleaning is necessary before each accurate inspection to find the correct location and the extent of the damage.
- B. Cleaning removes all the remaining particles, which can have an unwanted effect on the performance of the equipment. It also helps the possible repair.

TASK 25-23-08-940-802

2. Job set-up information

- A. Tools, Fixtures, equipment and materials

NOTE: Refer to “SPECIAL TOOLS, FIXTURES, EQUIPMENT AND MATERIALS” for full details on the items used.

REFERANCE	QTY	NAME
#PC-10	AR	NOVUS PLASITC POLISH
BRILLIANIZE	AR	CLEANER & POLISH
39139 (Prepsol)	AR	CLEANER FOR NON-FABRIC PARTS

Lou Martin & Assoc., Inc.
Component Maintenance Manual

TASK 25-23-08-100-802

3. Procedure

A. How to use Novus Plastic Polish No. 1

Remove surface dust with soft cloth. Shake bottle contents and apply a light mist. Spread evenly and buff with a clean, soft, lint-free cloth.

B. How to use BRILLIANIZE Cleaner & Polish

Shake contents firmly and apply evenly to any hard, shiny, non-absorbent surface at room temperature. Rub gently. Before surface dries, polish with a dry lint-free cloth or non-damaging material, until the surface feels “as smooth as ice”.



FIGURE 5/ GRAPHIC 25-23-08-991-005

Lou Martin & Assoc., Inc.
Component Maintenance Manual

C. Mask fabric

The lustrous feel of Ultra Suede HPC can be maintained by a light brushing with a medium bristle brush. In the event of a mishap, stains can be removed with detergent. Only when required use a mild cleaning fluid from your local hardware store.

Everyday Stains: Remove any free matter with knife or spoon. Pat the stained area with water and mild detergent. Remove detergent solution with a clean cloth and water. Dry on warm setting with hair dryer or naturally in the air.

Extremely Tough Stains: For severe stains such as automotive grease use a mild solvent. Moisten a clean cloth with a mild cleaning fluid. Pat the stained area until clean. Blot with a clean, dry cloth.

D. Shade fabric

Lou Martin easy-glide shade systems utilize a metallized fabric, which is inherently anti-static. They actually repel dust and seldom require cleaning. An occasional light sweep of a vacuum is all that should be needed.

In the event of a mishap, Lou Martin easy-glide shades may be cleaned with a mild detergent and water. However, water spotting can occur. If a detergent is required, we suggest a mild detergent such as woolite.

NOTE: Do not use ammonia cleaners near the Lou Martin easy-glide shade. Ammonia cleaners will damage the shade.

Lou Martin & Assoc., Inc.
Component Maintenance Manual

PAGE INTENTIONALLY LEFT BLANK

PAGE 5004
JAN 10/05

25-23-08

Lou Martin & Assoc., Inc.
Component Maintenance Manual

TASK 25-23-08-200-801

AIRWORTHINESS LIMITATIONS

1. General

- A. The Airworthiness Limitations section is FAA-approved and specifies maintenance required under §§43.16 and 91.403 of the Federal aviation regulations, unless an alternative program has been FAA approved.

Lou Martin & Assoc., Inc.
Component Maintenance Manual

PAGE INTENTIONALLY LEFT BLANK

PAGE 6002
JAN 10/05

25-23-08

Lou Martin & Assoc., Inc.
Component Maintenance Manual

INSPECTION/REPLACEMENT & REPAIR

TASK 25-23-08-300-801

1. General

- A. The procedures given in these chapters are general inspection and repair procedures and are not applicable to the riveted or welded parts. The manufacturer must repair the riveted or welded junctions, which are damaged.

TASK 25-23-08-940-803

2. Job set-up information

- A. Tools, fixtures, equipment and materials
- B. It is recommended that the completion center contact Lou Martin & Assoc., Inc. for replacement parts to insure quality and operation

NOTE: Assure window unit lenses, plated parts, decorative mask parts are protected at all times when work is being done.

(1) Repair materials

REFERANCE	QTY	NAME
#4945	AR	3M Acrylic foam tape
FMR-604 (.06 Thk.)	AR	Replacement outer lens
FMR-604 (.13 Thk.)	AR	Replacement inner lens
8-MIL CORD (WHITE)	AR	Replacement shade string
MS21044-N08	AR	Replacement stop nut
MS21044-N06	AR	Replacement stop nut
MS51092-6	AR	Replacement washer
MS51092-8	AR	Replacement washer
MS24693S-632	AR	Replacement screw
MS24693S-832	AR	Replacement screw
MS21059L08	AR	Replacement nut plate

Lou Martin & Assoc., Inc.
Component Maintenance Manual

TASK 25-23-08-200-801

3. Inspection of window unit

- A. When inspecting the window unit write all the damage detected, in some condition, the cause and/or the source. Immediately repair all the damage found.
- B. Visually check all hardware, detail parts and assemblies for the following criteria:
- (1) Wear, tears, fraying of the shade & decorative mask fabric.
 - (2) Tightening of the screws and nuts
 - (3) Condition of the Inner and Outer Lenses for scratches, cracks or spots.
 - (4) Condition of the reveal for scratches, chipping or fading of the paint.
- C. Do a careful check of all the parts for corrosion, distortion, incipient cracks, cracks, dents, nicks, scores, stripped threads, excessive wear, etc. which can damage the performance of the equipment and give it an unsatisfactory condition.

TASK 25-23-08-200-802

4. Replacement of Parts

After the replacement of an item, write a list of the defective parts you must replace and a list of the parts on which a repair or a new production is necessary.

Lou Martin & Assoc., Inc.
Component Maintenance Manual

TASK 25-23-08-350-801

5. Replacement procedure for outer lens (See FIGURE 6/ GRAPHIC 25-23-08-991-006)
 - A. Remove existing outer lens to be replaced. Note: Lens is attached w/ strong adhesive double-sided tape; some hard jerks may be required.
 - B. Remove used tape from reveal and clean surface with clean cloth damped with alcohol or prepsol.
 - C. Apply one layer of #4945 3M Acrylic foam tape to reveal, joining both ends of tape with a seam. (Do not overlay seam)
 - D. Locate new lens and decide which side of lens to be bonded to reveal. Remove this side's protective film before bonding. Note, use a static blow-off gun to eliminate dust attraction.
 - E. Center the lens at one end and work towards the top evenly on both sides pressing firmly for bonding. Go back and press additional strokes to assure full contact all around lens.
 - F. Check lens and assure it follows reveal contour. Assure center of lens is not sunk, if so re-attaching lens may be required.

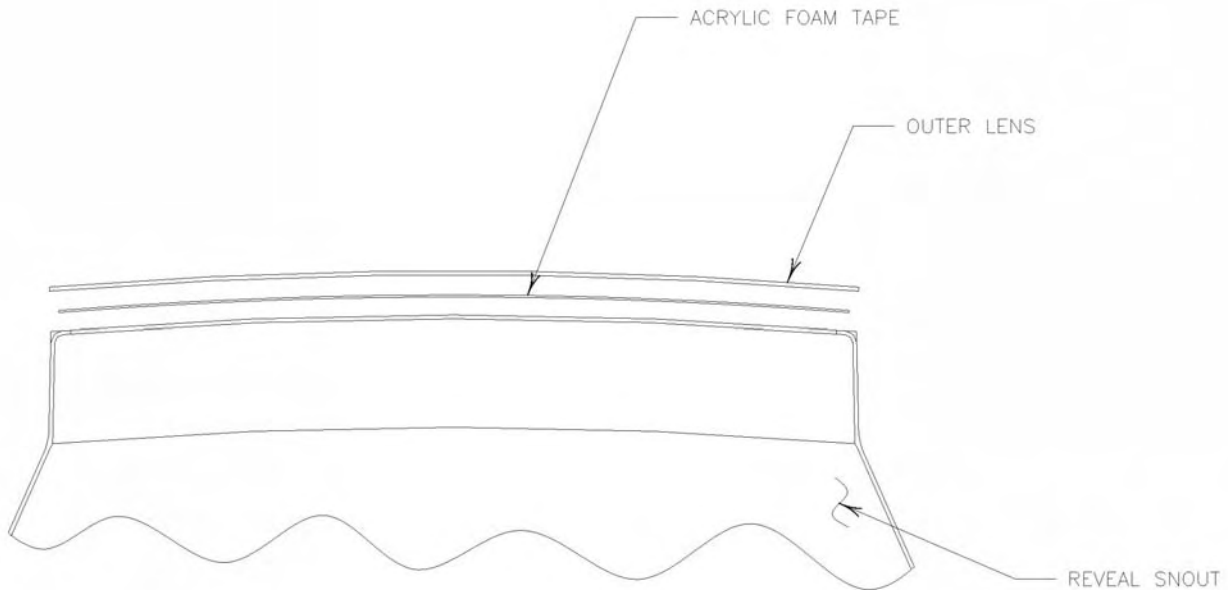

Windows reveal snout
FIGURE 6/ GRAPHIC 25-23-08-991-006

Lou Martin & Assoc., Inc.
Component Maintenance Manual

TASK 25-23-08-350-802

6. Replacement procedure for broken shade string

- A. For removal of blind mod. (See “DISASSAMBL Y”, section 6 page 4002)
- B. Remove broken string and replace with new string.
- C. Tie upper left screw at mid way thru string and run string thru shade assy. (See FIGURE 7/ GRAPHIC 25-23-08-991-007)
- D. Reinsert glides into slide track and reattach to reveal.
- E. Reattach upper blind mod. assy. (See “ASSEMBLY”, section 5 page 8002)

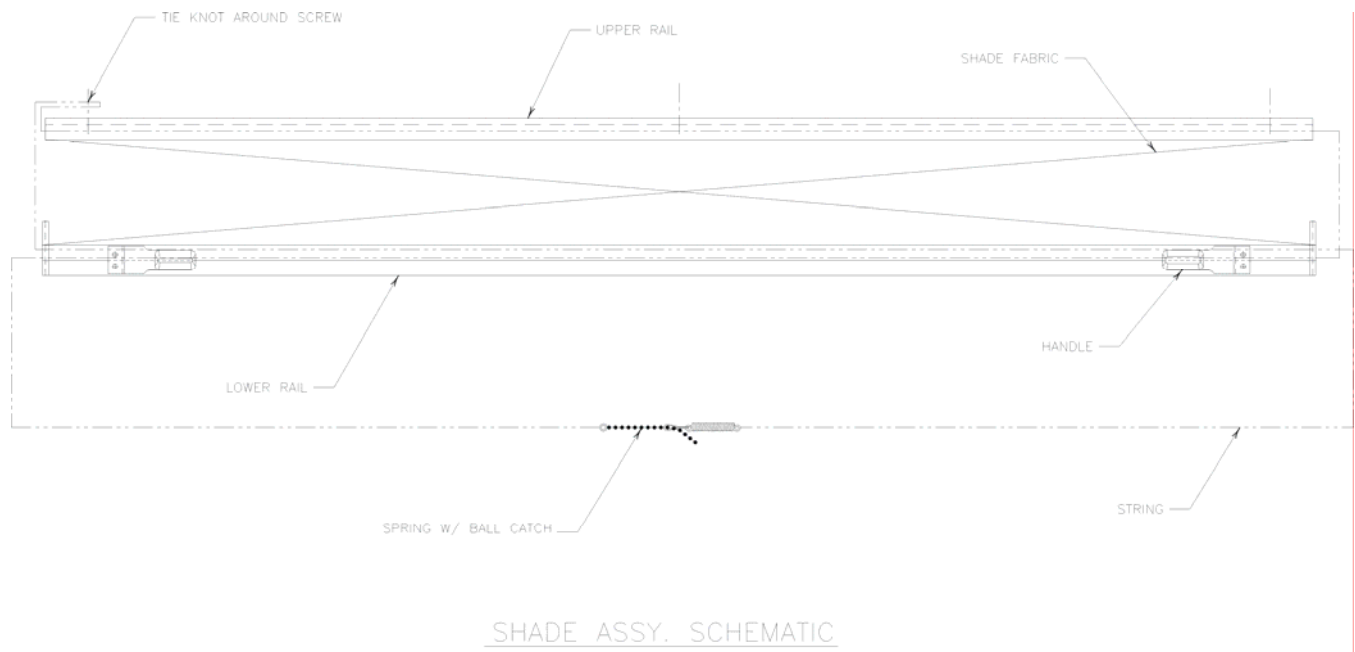

FIGURE 7/ GRAPHIC 25-23-08-991-007

Lou Martin & Assoc., Inc.
Component Maintenance Manual

TASK 25-23-08-350-803

7. Replacement procedure for a damaged inner lens
 - A. Remove decorative mask from window assy. (See “DISASSAMBLY”, section 4 page 4002)
 - B. Mark both sides of inner lens on reveal to assure replacement inner lens is properly located during reassembly.
 - C. Remove inner lens from window assy. (See “DISASSEMBLY”, section 5 page 4002)
 - D. Trim replacement inner lens to size, ref table for proper sizing. (See FIGURE 8/ GRAPHIC 25-23-02-991-008, Page 3) or match size w/ damaged inner lens.
 - E. Before attaching new lens decide which side of lens is to be attached to reveal. Remove this side’s protective film. Note: use a static blow-off gun to eliminate dust attraction.
 - F. Clamp replacement inner lens to window assy., assure lens follows window reveal’s contour. Note: it will help if the lower surface of lens is clamped first then force the lens to follow reveals contour then clamp upper lens surface. Test shade up & down to check for tension. Loose lens will ease the tension on the shade, if not refer to “Testing & Fault Isolation”
 - G. Attach new inner lens to window assy. Match drill lens with existing nut plate locations. Note: when drilling assure not to damage nut plates located on backside of reveal. Then remove clamps. (See “ASSEMBLY”, section 4 page 8002)



FIGURE 8/ GRAPHIC 25-23-08-991-008

Lou Martin & Assoc., Inc.
Component Maintenance Manual

ASSEMBLY

TASK 25-23-08-400-801

1. General

- A. Before the assembly, make sure that the CLEANING and the INSPECTION/REPAIR procedures of all parts are done.
- B. Where it is possible, it is recommended to use new parts and genuine approved parts.

TASK 25-23-08-940-804

2. Job set-up information

- A. Tools, Fixtures, equipment and materials

NOTE: Refer to SPECIAL TOOLS, FIXTURES, EQUIPMENT AND MATERIALS for full details on the items used.

REFERENCE	QTY	NAME
MS21044-N08	AR	Replacement stop nut
MS21044-N06	AR	Replacement stop nut
MS51092-6	AR	Replacement washer
MS24693S-632	AR	Replacement screw
MS24693S-832	AR	Replacement screw

Lou Martin & Assoc., Inc.
Component Maintenance Manual

TASK 25-23-08-440-801

3. Blind mod. Reattachment

- A. Reinsert the lower rail glides into their slide tracks at top of reveal and slide down approx half way.
- B. Reattach upper blind mod. to the reveal by inserting the upper rail's screws thru the two existing holes in the top of the reveal cavity, and secure with MS21044-N04 or MS21044-N06 stop nuts.

NOTE: Assure a proper attachment with a min. two threads protruding thru nylon nut.

- C. Rethread shade string thru eyelets at bottom of reveal and reattach string to spring & ball chain.
- D. Slide shrink tube & loop clamp over & past spring catch, re-connect spring and ball chain.
- E. To adjust tension to desired level see ("Testing and Fault Isolation, section 3 page 1003)
- E. Slide loop clamp & shrink tube to cover tension assy
- F. Re-attach loop clamp to retainer clip and secure in place w/ MS21044-N06 stop nut.

TASK 25-23-08-440-802

4. Inner lens reattachment

- A. Reattach inner lens with MS24693S-832 screw and pick-up existing nut plate (8 places)
- B. Remove protective film from inboard side of lens prior to reattaching decorative mask.

Lou Martin & Assoc., Inc.
Component Maintenance Manual

TASK 25-23-08-440-803

5. Decorative mask reattachment

- A. Place the mask over the window assy. and align decorative handle's holes with the lower blind mod. attachment holes and attach using MS24693S-632 screw (2)
- B. Align the attachment holes of the backside of reveal with those of the decorative mask, attach decorative mask with MS27039-832 screw pick-up existing insert (5 places)

Lou Martin & Assoc., Inc.
Component Maintenance Manual

FITS AND CLEARANCES

TASK 25-23-08-820-801

1. General

- A. The listed clearances are to insure the window is properly installed into the aircraft

TASK 25-23-08-820-802

2. Clearances

- A. Assure a min. clearance of .063 in. (1.59 cm) between the window shade assy. and existing structure.
- B. Assure a min. clearance of .13 in. (3.18 cm) between the window assy's outer lens and the inboard side of the aircraft's existing pressure lens.
- C. Assure a min. clearance of .04 in. (1.02 cm) between each decorative mask fwd & aft in the aircraft.

Lou Martin & Assoc., Inc.
Component Maintenance Manual

PAGE INTENTIONALLY LEFT BLANK

PAGE 9002
JAN 10/05

25-23-08

Lou Martin & Assoc., Inc.
Component Maintenance Manual

SPECIAL TOOLS, FIXTURES, EQUIPMENT

TASK 25-23-08-940-805

1. Special tools, fixtures and equipments

No special tools, fixtures and equipment are necessary for the maintenance or the overhaul to be performed on the standard equipment.

Standard tools are used for these operations.

Lou Martin & Assoc., Inc.
Component Maintenance Manual

STORAGE

TASK 25-23-08-940-806

1. General

- A. When any of the window assay's need to be removed from the aircraft, Lou Martin & Assoc., Inc. recommends to stow the shade is in the up position.
- B. Store in a sheltered, ventilated place with normal hygrometric degree (70%)
- C. Cover the window unit with large clean plastic bags or equivalent to protect it from dust and other airborne particles.
- D. On the outside of the bag or cover add a tag with its location in the aircraft for tracking purposes and quicker reinstallation in the aircraft.

Lou Martin & Assoc., Inc.
Component Maintenance Manual

PAGE INTENTIONALLY LEFT BLANK

PAGE 11002
JAN 10/05

25-23-08

Lou Martin & Assoc., Inc.
Component Maintenance Manual

ILLUSTRATED PARTS LIST

TASK 25-23-08-950-801

1. Introduction

A. General

- (1) The Illustrated Parts List (IPL) intends to show the details of the equipment and permits easy provisioning of the spares necessary for the maintenance of this equipment.

B. Use of the illustrated parts list

- (1) “Introduction” section

The introduction contains all explanatory information for the individual sections necessary for the use of this IPL.

- (2) “Illustrated Parts List” section

The detailed parts list gives the list and the illustrations of parts making up the considered assembly. The different columns of the parts list pages are organized as follows:

- 1st column: Figure and item number
- 2nd column: Manufacturer’s part number
- 3rd column: Airline part number (not used)
- 4th column: Indenture
- 5th column: Designation
- 6th column: Usage from to
- 7th column: Quantity per Assembly

- (a) Figure and item number

1 Each illustration receives a figure number starting at 01 and carrying on in sequence.

2 Each illustration can be divided up into several folios

3 When it is necessary to add figures, alphabetic indexes are added to the original figure, from A to Z, except I and O

INTRO IPL
PAGE 1
JAN 10/05

Lou Martin & Assoc., Inc.
Component Maintenance Manual

- 4 An item number is attributed to each part mentioned in the detailed parts list. Numbers start at 001A up to 999A per sequence of 10 by 10 or else in order to insert additional items.
- 5 Alternative parts have the same item as the initial part and are indexed.
- 6 To follow the evolution of the standard of parts or assemblies modification, items are indexed from B to Z, except I and O.
- 7 Non-illustrated items are identified by a dash placed in front of the item.

(b) Manufacturer's part number

This column indicates the original manufacturer's part number or the part manufacturer.

(c) Airline part number

This column is left blank; it is reserved for the airline.

(d) Indenture

The designation is presented according to indentations indicating as follows the relation between the different components:

- 1 Assembly
- 2 Sub-assemblies
- 2 Attaching parts of the sub-assembly
- 3 Constitutive parts of the sub sub-assembly
- 3 Attaching parts of the sub sub-assembly
- 4 Constitutive parts of the sub subassembly
- Etc.

Lou Martin & Assoc., Inc.
Component Maintenance Manual

(e) Designation

The designation of the item can be followed by:

- The CAGE manufacturer's code,
- Cross-references indicating numbers, figures, items where this very item is illustrated.

(f) Usage from to

The interchangeability relation of constitutive parts according to the higher assembly is identified by the item number.

This code is only valid for the assembly dealt with in the corresponding figure.

Example:

FIG-ITEM	PART MUMBER	AIRLINE PART NUMBER	I N D	NOMENCLATURE	USAGE FROM TO	UNITS PER ASSY.
- 1A	PN1		1	ASSEMBLY 1		RF
- 1B	PN2		1	ASSEMBLY 2		RF
- 1C	PN3		1	ASSEMBLY 3		RF
10A	SPN1		2	SUB-ASSEMBLY 1	1AC	1
10B	SNP2		2	SUB-ASSEMBLY 2	1B	1
20A	SSNP1		3	SUB SUB-ASSEMBLY 1	10A	1
20B	SSPN2		3	SUB SUB-ASSEMBLY 2	10B	1
30A	SPN3		2	SUB-ASDSEMBLY 3		1

Lou Martin & Assoc., Inc.
Component Maintenance Manual

(g) Quantity per assy.

This column gives the number of parts required for an immediately higher assembly.

If a same assembly or a same part appears in several figures, the quantity is only given in the first parts list; the RF abbreviation appears in the following parts list.

If the quantity of a component is to be established as required (EX. seal, etc.) the quantity is replaced by the term AR (as required)

(2) How to use the Illustrated Parts List

(a) When the part number is known:

1 Turn to the numerical index and locate the part number.

2 The figure and item number on the illustration where the part appears are listed in the column to the right of the part number.

3 The corresponding item number in the accompanying parts list will give part number, description, assembly relationship and quantity required for that particular application.

(b) When the part number is not known:

1 Look through the illustrations and find the assembly of which the component is part, or look through the illustrations and identify the part by appearance. Note the item number in the exploded view and find part, description and quantity required for that part.

Lou Martin & Assoc., Inc.
Component Maintenance Manual

(5) List of abbreviations

The following abbreviations have been used in this CMM:

AR	As Required. Indicates that an indefinite quantity is required
ASSY	Assembly
CMM	Component Maintenance Manual
CAGE CODE	Commercial and Government Entity Code
DET	Detail
FIG	Figure
H	Horizontal
IND	Indenture
IPL	Illustrated Parts List
LH	Left Hand
NHA	Next Higher Assembly
NP	After any description means that this part number constitutes an assembly of breakdown parts not supplied as a whole. Although not procurable, a view of each assembly, sub-assembly, sub-sub-assembly, or small unit, exploded as necessary to show detail parts, is provided to illustrate each part in the detail parts list. Illustrations of all parts will be technically correct in assembly installation relation ships.
QTY	Quantity
RF	Reference indicates those parts which have their quantity listed elsewhere in the Illustrated Parts List.
R	Recline
RH	Right Hand
SYM	Symmetrical
V	Vertical

Lou Martin & Assoc., Inc.
Component Maintenance Manual

PAGE INTENTIONALLY LEFT BLANK

INTRO IPL
PAGE 6
JAN 10/05

3. Alphanumerical index

25-23-08

Lou Martin & Assoc., Inc.
Component Maintenance Manual

PART NUMBER	AIRLINE STOCK NUMBER	FIGURE	ITEM	TTL REQUIRED
00-113M004-11		10	140	2
00-113M004-13		10	120	2
00-113M014-3		12	40	2
00-113M014-5		12	10	2
00-113M014-55		12	20	AR
00-113M022-5		9	050	2
875-XXXX		10	20	AR
#9485PC		10	80	AR
A319-113M001-51		13	20	3
A319-113M004-XX		9 12	010 30	1
A320-113M2165-XX		9	030	1
A320-113M2165-41 AND -43		9 10	020 70	2 2
A320-113M2165-91		10	10	2
A320-113M2165-XXX		9	060	1
A320-113M2165-XXX		9	040	1
A320-113M2165-93		12	50	AR
A320-113M2165-109		9	070	2
		10	90	2
D7-XXX		10	30	1

ALPHANUMERICAL INDEX
PAGE 1
JAN 10/05

PART NUMBER	AIRLINE STOCK NUMBER	FIGURE	ITEM	TTL REQUIRED
-------------	----------------------	--------	------	-----------------

25-23-08

Lou Martin & Assoc., Inc.
Component Maintenance Manual

SUPPLIED W/ REVEAL		13	10	AR
MS21044-N06		10	40	AR
MS24693-440		12	30	AR
MS24693S-632		10	60	AR
		10	100	AR
		12	60	AR
MS51092-6		10	50	AR
NAS1836-07-12		13	30	3
NAS1836-08-07		11	20	4
NAS548-P6		10	130	4

ALPHANUMERICAL INDEX
PAGE 2
JAN 10/05

Lou Martin & Assoc., Inc.
Component Maintenance Manual

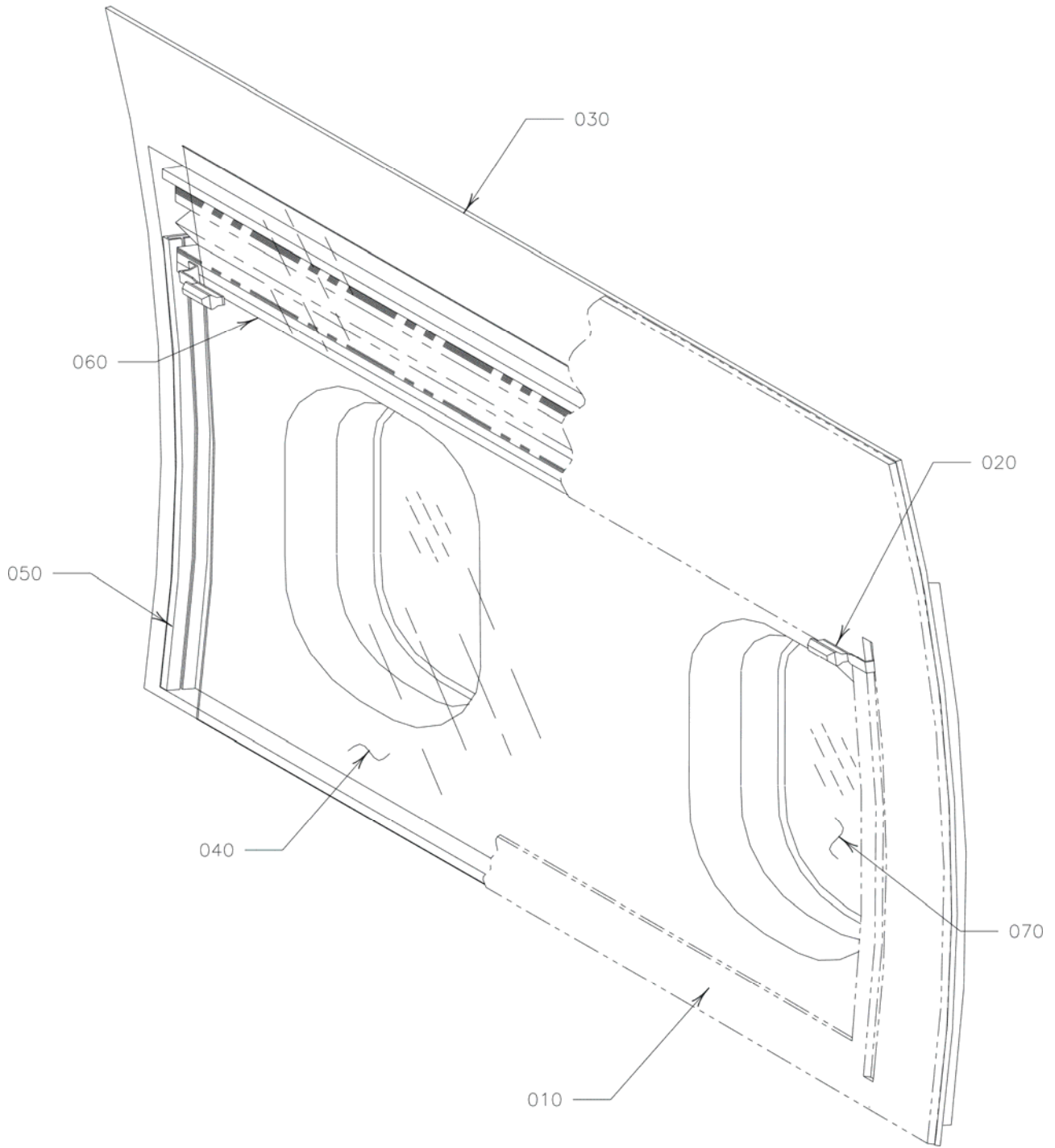

Decorative Window Shade Assy.
FIGURE 9/ GRAPHIC 25-23-08-991-009

Lou Martin & Assoc., Inc.
Component Maintenance Manual

9 FIG-ITEM	PART NUMBER	AIRLINE PART NUMBER	I N D	NOMENCLATURE	USAGE FROM TO	UNITS PER ASSY.
010	A319-113M004-XX		2	DECORATIVE MASK		1
020	A320-113M2165-41 THRU -43		3	HANDLE ASSY.		2
030	A319-113M001-XX		1	WINDOW REVEAL		1
040	A320-113M2165-XX		1	INNER LENS		1
050	00-113M022-5		1	SLIDE TRACK ASSY.		2
060	A320-113M2165-XX		2	BLIND MOD. ASSY.		1
070	A320-113M2165-109		1	OUTER LENS		2

Lou Martin & Assoc., Inc.
Component Maintenance Manual

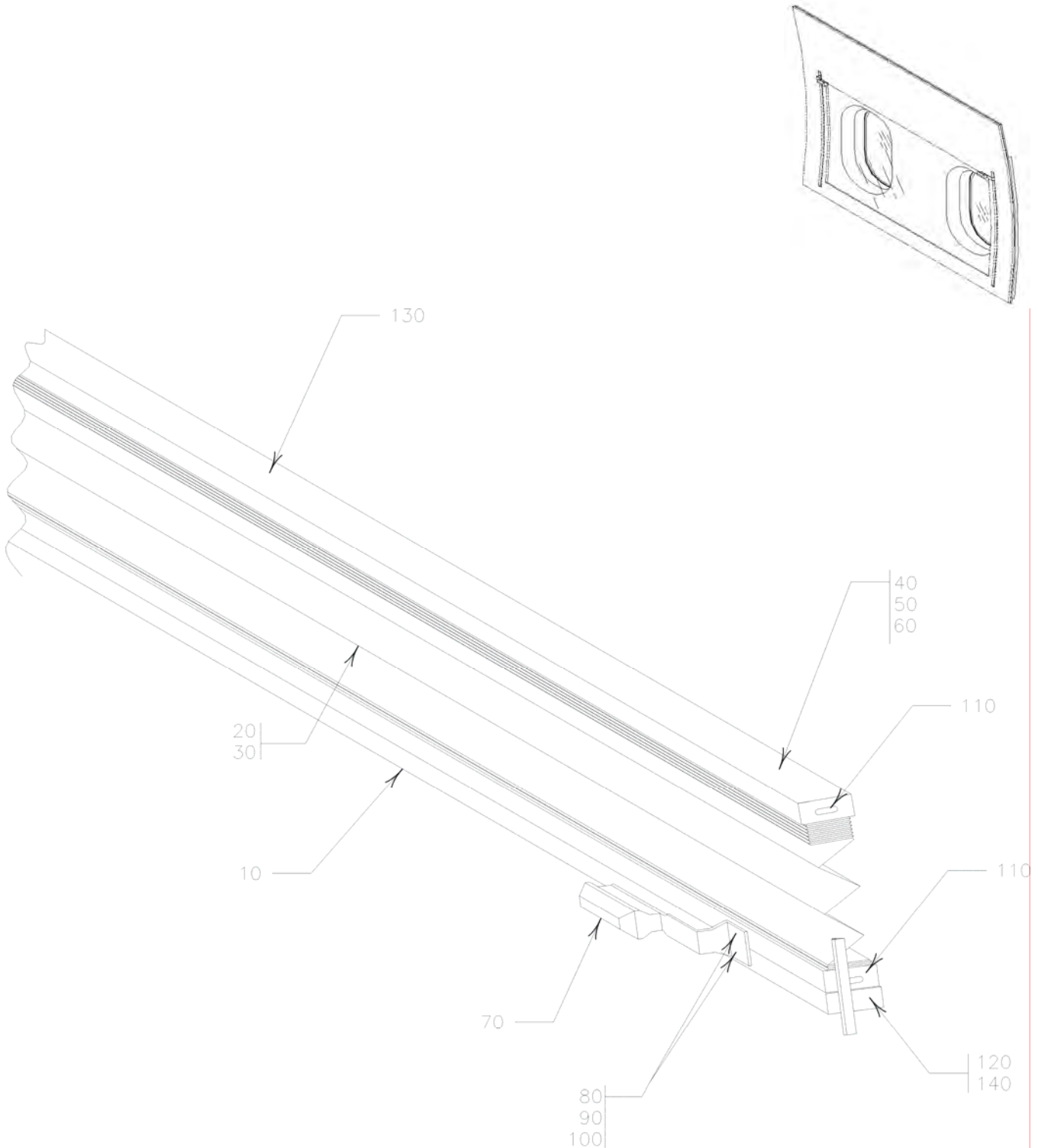

Blind Mod. Assy.
FIGURE 10/ GRAPHIC 25-23-08-991-010

Lou Martin & Assoc., Inc.
Component Maintenance Manual

10 FIG-ITEM	PART NUMBER	AIRLINE PART NUMBER	I N D	NOMENCLATURE	USAGE FROM TO	UNITS PER ASSY.
10	A320-113M2165-91		1	LOWER RAIL		2
20	875-XXX		1	SHADE FABRIC (OUTBOARD)		1
30	D7-XXX		1	SHADE FABRIC (INBOARD)		1
40	MS21044-N06		1	STOP NUT		AR
50	MS51092-6		1	WASHER		AR
60	MS24693S-632		1	SCREW		AR
70	A320-113M02165-41		1	HANDLE ASSY.		2
80	AND -43 #9485PC		1	3M DOUBLE SIDED TAPE		AR
90			1	.05 THK. ALUM. SPACER		2
100	MS24693S-632		1	SCREW		AR
110	SUPPLIED W/ BLIND		1	END CAP		4
120	00-113M004-13		2	WOOD BLOCK		2
130	SUPPLIED W/ BLIND		1	UPPER RAIL		1
140	00-113M004-11		1	GLIDE		2

Lou Martin & Assoc., Inc.
Component Maintenance Manual

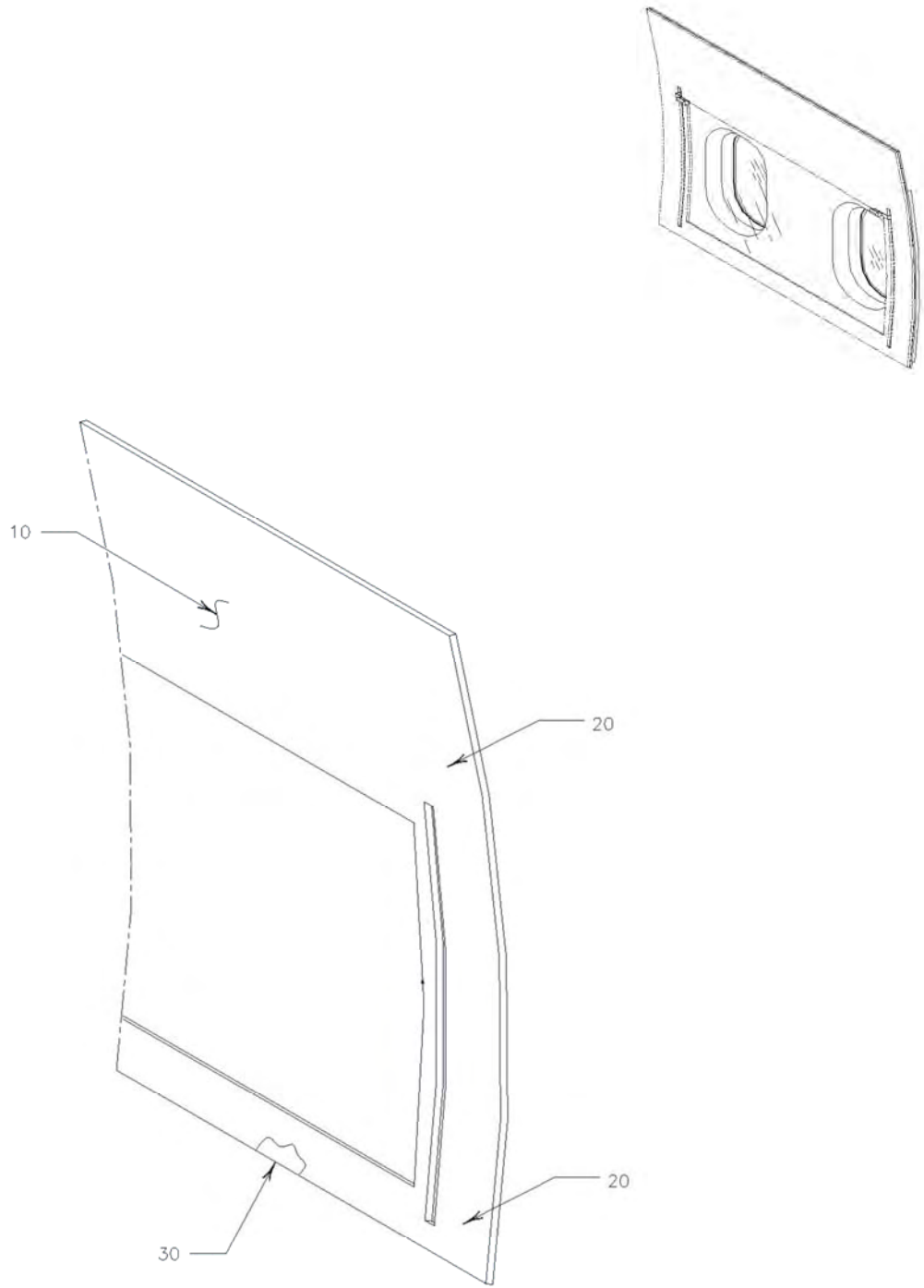

Decorative Mask. Assy.
FIGURE 11/ GRAPHIC 25-23-08-991-011

Lou Martin & Assoc., Inc.
Component Maintenance Manual

11 FIG-ITEM	PART NUMBER	AIRLINE PART NUMBER	I N D	NOMENCLATURE	USAGE FROM TO	UNITS PER ASSY.
10	SUPPLIED BY CUSTOMER		1	DECORAITVE FABRIC		AR
20	NAS1836-08-07		1	INSERT		4
30	A319-113M004-XX		1	FIBERGLASS PANEL		1

Lou Martin & Assoc., Inc.
Component Maintenance Manual

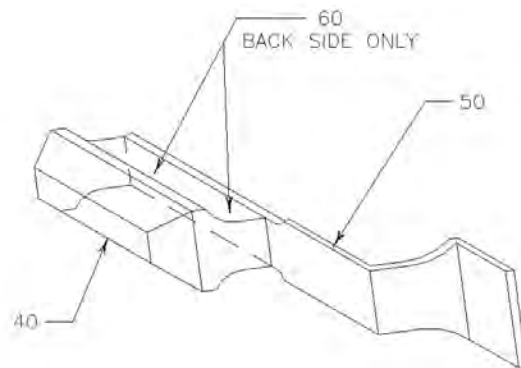
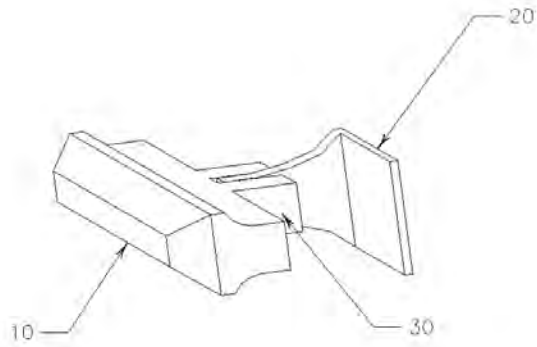
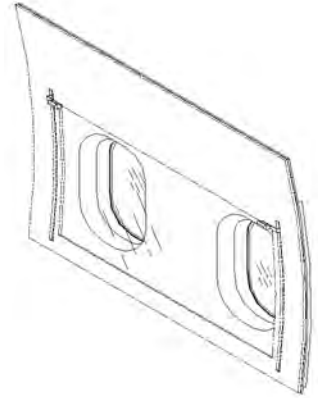

Handle Assy.
FIGURE 12/ GRAPHIC 25-23-08-991-012

Lou Martin & Assoc., Inc.
Component Maintenance Manual

12 FIG-ITEM	PART NUMBER	AIRLINE PART NUMBER	I N D	NOMENCLATURE	USAGE FROM TO	UNITS PER ASSY.
10	00-113M014-5		1	HANDLE		AR
20	00-113M015-55		1	RETAINER		AR
30	MS24693S-440		1	SCREW		AR
40	00-113M014-3		1	HANDLE		AR
50	A320-113M2165-93		1	RETAINER		AR
60	MS24693S-632		1	SCREW		AR

Lou Martin & Assoc., Inc.
Component Maintenance Manual

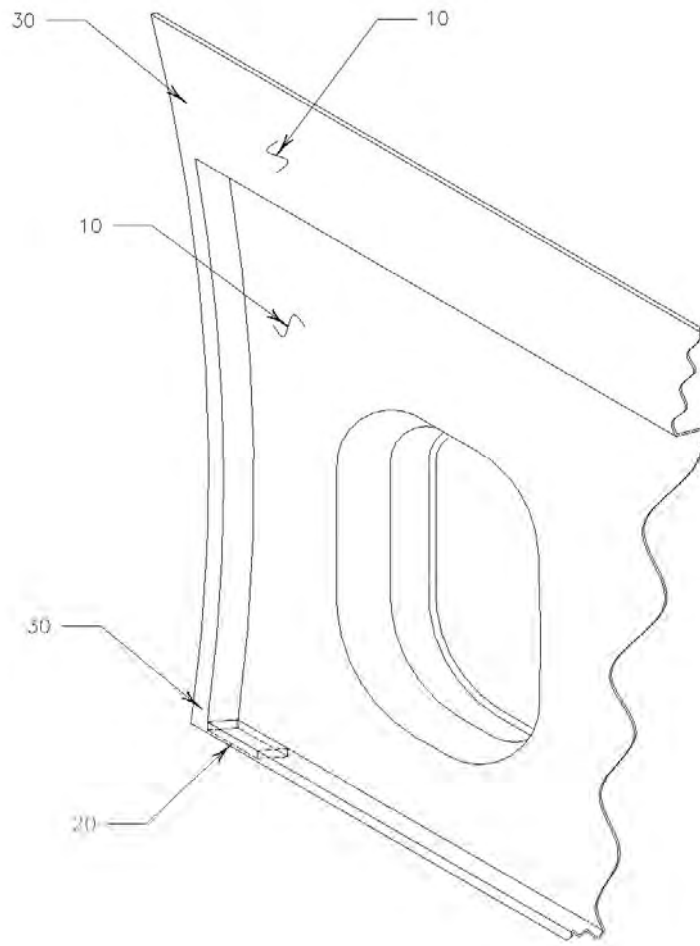
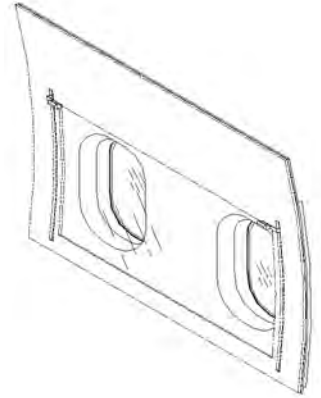

Handle Assy.
FIGURE 13/ GRAPHIC 25-23-08-991-013

Lou Martin & Assoc., Inc.
Component Maintenance Manual

13 FIG-ITEM	PART NUMBER	AIRLINE PART NUMBER	I N D	NOMENCLATURE	USAGE FROM TO	UNITS PER ASSY.
10	SIPPLIED WITH REVEAL		1	.25" FOAM CORE		AR
20	A319-113M001-51		1	BLOCK		AR
30	NAS1836-07-12		1	INSERT		AR